



# THE TRANSMITTER

## SUBURBAN R.C. BARNSTORMERS INC.

PUBLISHER / EDITOR ORVIL T. FLUHARTY

AMA CHAPTER #640

PRESIDENT : James Scabill

IMAA CHAPTER #194

VICE-PRESIDENT: Scott Taylor

SECRETARY: Sandy LaRocco

TREASURER: Larry Mihalik

APRIL 1992

### INSIDE

2

HOBBY SHOPS  
NAME THE PLANE

3

MEETING MINUTES  
MARCH 12TH 1992

4

MINUTES MAR. 20TH  
HOBBY SHOPS

5

SWAP SHOP REPORT

6

SWAP SHOP REPORT

7

LOOK ALIKES  
PROFILES

8

BATTERY BACK UP

9

FREQUENCY SURVEY  
LOCAL SWAP SHOP

## APRIL MEETINGS...

APRIL 9th : Business Meeting  
Bloomingdale Public Library

APRIL 23rd: **STATIC CONTEST**  
Bloomingdale Public Library

## AND THERE WERE RULES!!!!

As it was last year so it will be this year. The rules for the Barnstormers annual static contest will be that to enter a plane you must have done 50% of the work.

### YOU WILL NOT BE ABLE TO ENTER

- IF YOU DID NOT DO 50% OF THE WORK
- IF YOUR PLANE HAD A PREVIOUS 1ST PLACE FINISH

## WELCOME....

A BIG WELCOME TO NEW MEMBER.  
ALLAN BREESE OF STREAMWOOD

## FLYING FIELD !!!

AS OF PRESS TIME THE FIELD WAS STILL CLOSED BUT DID SHOW SIGNS OF BEING OPENED SOON.....

## IMPORTANT!

### CLUB FUEL ORDER

I have picked up the fuel and my wife would like very much if I would get in excess of one hundred and fifty gallons out of our garage. So I will be in the Library parking lot at 6:30 Thursday April 23rd. If you can't make it maybe a friend can pick it up for you.

thank you.... Orvil

## PRESIDENT'S CORNER....



I would like to take this opportunity to thank all the members that helped out at the swap shop, your kindness and concern for our club made this one the best ever. Just wait till next year!

I also would like to thank Ron Walker for a great demonstration on fibreglassing. It was very thorough and very helpful to all the members that needed a little help in that area.

Last but not least; hopefully by the time you read this newsletter we will have our flying field back, so go out there and have a great season!!! **THINK SAFETY!**

*Hime*

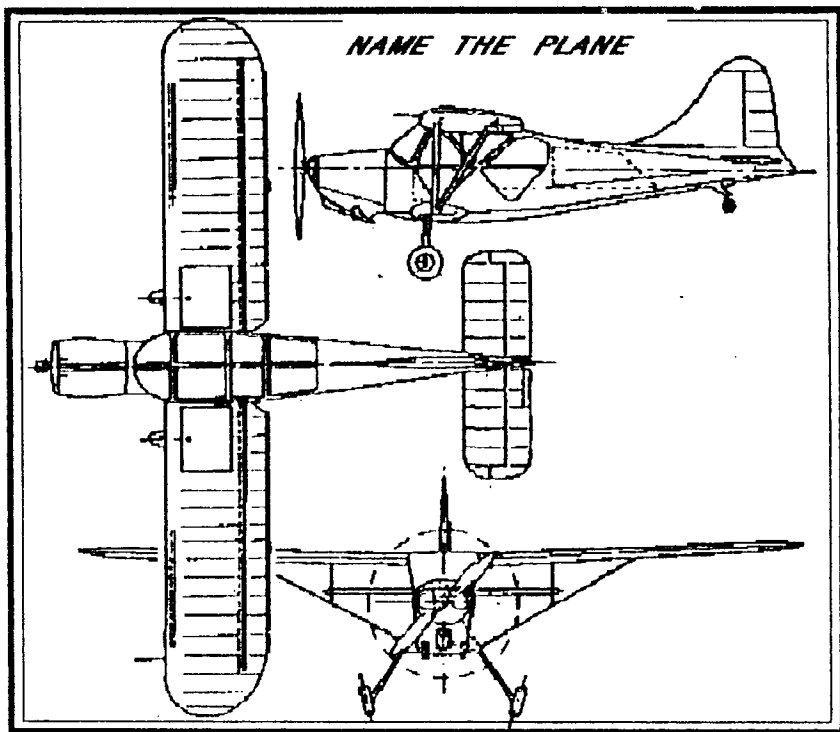

**WE WOULD LIKE TO  
WELCOME THREE  
NEW HOBBY  
STORES TO OUR  
NEWSLETTER**

**HANGER HOBBIES**

**HOBBYTOWN USA**

**HOBBY WORKS**

supplies CORPS MODELS

**HANGER HOBBIES**

ROCKETS PLANES TRAINS

2835 KIRCHOFF RD.  
ROLLING MEADOWS 708-670-7738

**Hobbytown USA**  
Arlington Heights, IL 60004

ART & JIM WEREN, Owners  
Naperville Plaza  
504 South Route 59  
Naperville, IL 60540

Phone (708) 778-8707  
Fax (708) 778-8681

See our Franchise Store Nationwide!

708.406.9400  
FAX 708.406.9477

HOBBY WORKS, INC.

Jim Debow  
Owner

163 West Wilson Street  
Burlington, Illinois 60510

(708) 832-4908  
FAX: (708) 832-3812

STORE HOURS:  
MONDAYS 12:00 TO 3:00 P.M.  
TUES, WED & FR 3:30 TO 5:30 P.M.  
THURS 8:30 TO 9:00 P.M.  
SATURDAYS 9:00 TO 5:30 P.M.

**AL'S** AL'S HOBBY SHOP INC.  
Box 449  
121 Addison  
Elmhurst, Illinois 60126

Complete Line Of Hobbies

Mon 11:00 - 6:00  
Tue - Fri 12:00 - 8:00  
Sat 10:00 - 5:00

**ARLINGTON HOBBIES**  
"The Right Connection"

218 N. Dunton  
Arlington Hgts., IL 60004 255-7383

**PMC MODEL-TRONICS**

Peter M. Calvagna  
1092 W. Becker School Road  
Freeport, Illinois 61032  
United States of America  
815/233-5646

**DOWNERS GROVE HOBBIES**

"LGB and RC OUTFITTERS"

GREEN KNOLLS SHOPPING CENTER  
6238 SOUTH MAIN STREET  
DOWNERS GROVE, IL 60515  
Jerry & Bob Wawro (708) 950-5900

RADIO CONTROL GAMES WORKSHOP PRODUCTS  
Planes • Cars ROCKETS • TRAINS  
Boats

**G & J HOBBIES**  
ARLANS LARGEST SELECTION OF ANTIQUE TRAINS  
(708) 695-9924

385 E. State St.  
South Elgin, IL 60177 GIGI & JACK VIRGIN  
Proprietors

**THE TRANSMITTER**

This newsletter is published monthly by the SUBURBAN RC BARNSTORMERS INC. We reserve the right to edit all information forwarded to us. Permission is hereby given to reprint any article that we publish as long as proper credit is given. Please submit all material to be printed by the 25th of the month preceding publication. Submit articles to:

Orvil Fluharty  
899 Carl Ave  
Elgin IL 60120

Submitted material will not be returned unless requested.

WE BUY, SELL, TRADE  
LIONEL TRAINS AMERICAN FLYERS HO TRAINS  
LGB TRAINS ALSO MODEL KITS RC EQUIPMENT

**ORLAND HOBBIES**

240 SOUTH WESTMORE LOMBARD, IL 60148  
18952 OAK PARK AVE. TINLEY PK., IL 60477

GENE NIE  
708-953-8447  
ED STANLEY  
708-429-9911

R.C. PLANE, CARS BOATS, & TRAINS

**TEAM HOBBIES**

PRAIRIE TRAIL CENTER  
GENEVA & COUNTY FARM RDS.  
27 W. 218 GENEVA RD.  
WINTELD, IL 60190 682-5555

DENNIS BREEN, President

**FALKERS HOBBY SHOPPE**

802 E. Main Street  
St. Charles, IL 60174  
(708) 584-3611

**World Hobbies**  
RADIO CONTROLLED BOATS, PLANES, CARS

GENE CHONKO

330 N. Elm Street  
W. Dundee, IL 60118 428-4340

# MEETING MINUTES

by Sandy

Meeting minutes for 3-12-92.

Meeting started at 7:35 PM, we had 72 members present. We had two new members and one guest present. And yes, for the first time we had to start a little late, we were going crazy.

## OFFICERS REPORTS:

**PRESIDENT:** Jim said he went to the field and they are installing a new tunnel. He also is going to find out if the field can be seeded while the repairs are being done. He also noted he had nothing to do at the meeting, but Orvil was nice enough to put him to work until his arms got tired. Scott was taking fuel orders, Larry was collecting new memberships and raffle ticket money, and I was getting membership cards ready and I can't remember what else. Jim also wants everyone to remember to renew your AMA and get your Forest Preserve permit (even though the field is closed).

**VICE PRESIDENT:** Scott took fuel orders on his computer. Now that was neat.

**TREASURER:** Larry advised us we have 128 members to date. He also advised us we sold 980 raffle tickets. At the Swap Shop tickets will be 6 for \$5.00 so everyone can buy some more. He had no idea on the budget, he will advise us after the Swap Shop. I hope it is a great success. **SECRETARY:** By now you all know that the field is closed and should have rec'd a letter from the Forest Preserve. If you didn't I have a copy. Also please renew your AMA if you have'nt already.

## NO COMMITTEE REPORTS:

NO FIELD!

**MISC:** We are going to buy new cones for the

field. Eric got a very good deal on them. Everyone voted on it and of course it passed. The Swap Shop is March 14th. Orvil advised us we have 81 tables reserved so far. We have '93 tables available. Two tables will be available for club members, and you must take turns watching them if you put something on it. Set up is at 7:00AM. Also in case you have'nt heard St. Charles cancelled their Swap Shop. We spent \$270.00 on food so far for Swap Shop. Please come and help at the Swap Shop. Ron Walker is working on a training class he will have it done soon.

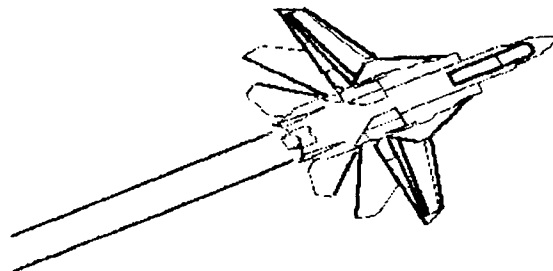

**PLANES AT THE MEETING:** As usual we had three very nice planes brought in. Tom Lyons brought in his 4-40. It is powered by a Saito 50. He has some really bright colors on this plane. He has Captain Eddie for his pilot. Bob DeMeritt brought in his Arrow Star 40. Very nice building job. Eric Bergstrom brought in his Auto Gyro. Yes, it flys. It has a K&B 40 (Eric said this is his POWERHOUSE engine) for power. He said "It sound like a cross between a Hoover vacuum cleaner and a Toro power mower." Door prizes were won by Dave Bella, Paul Krella Sr., Mike Gulley, Simon Hernadez and Bob Hellem. Gus was picked but he left early. Sorry Gus. No winner in roll over. Meeting adjourned at 8:27.

## MEETING MINUTES FOR 3/26/92.....

Meeting started at 7:34 PM. We had 66 members present for a great demonstration given by Ron Walker on fibreglassing and an entertaining video tape that Russ Carlson brought in from the Winter Fun Fly.

Orvil wants to THANK everyone who helped out at the Swap Shop and everyone who brought a model for the static display. THANKS to everyone it was a great success. We sold 99 tables out of 101. I am sure we would all like to thank Orvil (at least I would) for all the help he gave and for putting the Swap Shop on, he did a great job as usual. Larry said we did very well on raffle tickets and admissions. The club made over \$1,600.00 (see more info. in this newsletter). Scott will give us an update on the frequency survey he did. Orland Hobbies has some good deals on radios, fuel and monocoat. Also Scott reserved the AMA scanner for August 23th which is the IMAA Veteran's Memorial Fly-In. I advised

everyone that Bryon Expo will be on again. It will be August 1993 in Ankeny, Iowa. The field will re-open May 3th. The rocket people have the field reserved May 30th and 31st.

**PLANES :** Ralph Niedzwiecki brought in his electric cub. Butch Perkis brought in his Midwest AeroSport powered by a OS surpass 90. It weighs 7 1/2 lbs. It has a 16 oz. fuel tank. And Butch said "It flys like a bat out of Hell". Keith Burns brought in his Tucano. This is a Braziliam made plane. (If anyone can find info. on it please give it to Keith.) It is powered by a OS50FSR. It weighs 6 3/4 lbs. Keith said "It lands at about 40 mph". Chuck Pazdzioch brought in his Ace SeaMaster 40. It is for sale \$150.00. Rollover was won by Paul Krella Jr. (Sorry DAD) Congratulations Paul. It was a 6 channel FM radio. Meeting adjourned at 9:10.



## **A SPECIAL THANKS FOR YOUR SWAP SHOP DOOR PRIZE DONATIONS**

RADIO CONTROL  
Planes • Cars  
Boats

GAMES WORKSHOP PRODUCTS  
ROCKETS • TRAINS



### **G & J HOBBIES**

AREAS LARGEST SELECTION OF ANTIQUE TRAINS

(708) 695-5524

395 E. State St.  
South Elgin, IL 60177

GIGI & JACK VIRGIN  
Proprietors

Complete Line Of Hobbies

Mon 11 00 - 5 00  
Tues - Fri 12 00 - 8 00  
Sat - 10 00 - 5 00



**ARLINGTON HOBBIES**

"The Right Connection"

218 N. Dunton  
Arlington Hgts., IL 60004

255-7383

SWAP SHOP ANALYSIS 1992

EXPENSES		1990	1991	1992
RAFFLE	Raffle Tickets	\$95.00	\$204.50	\$159.95
	Raffle Prizes	\$293.00	\$310.90	\$469.48
	Door Prizes	\$0.00	\$80.00	\$125.00
	Raffle for Helpers	\$0.00	\$85.00	\$0.00
	RAFFLE TOTAL	\$388.00	\$680.40	\$754.43
STATIC	Plaques and Ribbons	\$66.00	\$68.98	\$74.28
	Cash Prizes	\$75.00	\$155.00	\$140.00
	STATIC TOTAL	\$141.00	\$223.98	\$214.28
FOOD	Food/Drink	\$185.00	\$213.90	\$253.12
RENT	Hemmans Rental	\$671.00	\$669.00	\$760.00
	Elgin Head Tax	\$68.00	\$89.50	\$116.50
	RENT TOTAL	\$739.00	\$758.50	\$876.50
OTHER	Postage	\$55.00	\$90.00	\$120.00
	Misc	\$46.00	\$57.00	\$75.00
	TOTAL OTHER	\$101.00	\$147.00	\$195.00
TOTAL EXPENSES		\$1,554.00	\$2,023.78	\$2,293.33
INCOME				
ADMISSIONS		296	358	466
		\$882.00	\$913.00	\$1,202.00
TABLE SALES		\$335.00	\$529.00	\$722.00
FOOD INCOME		\$400.00	\$535.00	\$596.25
RAFFLE TICKET SALES		\$1,206.00	\$1,188.00	\$1,394.00
TOTAL GROSS INCOME		\$2,823.00	\$3,165.00	\$3,914.25
NET INCOME		\$1,269.00	\$1,141.22	\$1,620.92
ROI		1.82	1.56	1.71

SWAP TIL' YOU DROP IV

INCOME

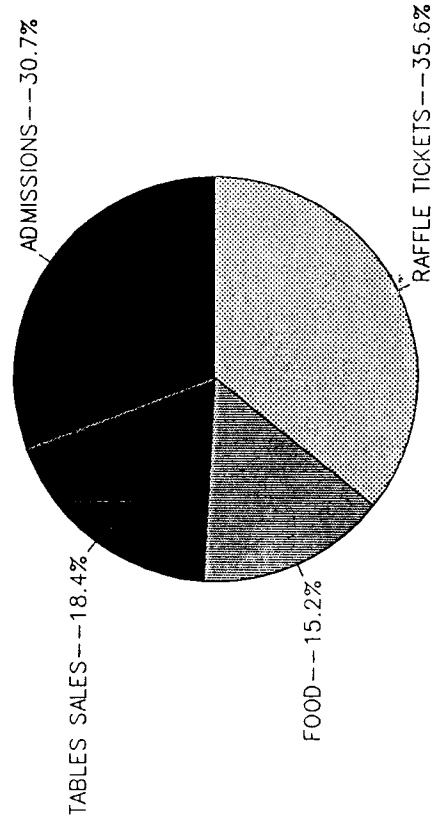

INCOME SOURCES

SWAP TIL' YOU DROP IV

EXPENSES

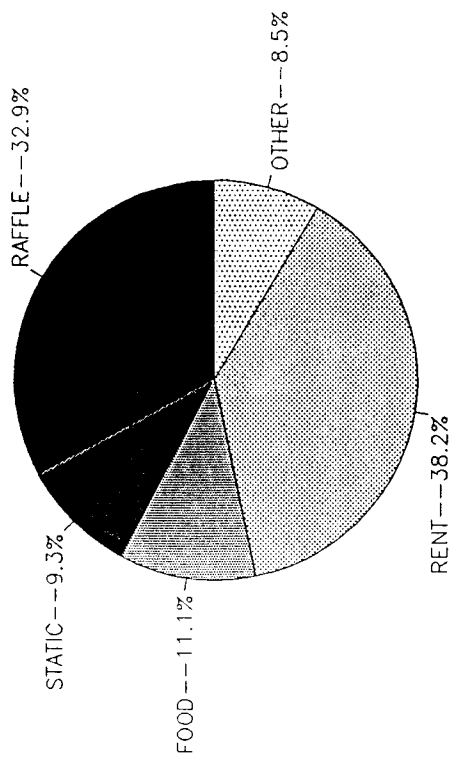

Outgoing Expenses

## **"LOOK ALIKES"**

by Gus Pasquini

Just the other weekend I was flying my "TURTLE" plane, enjoying the weather and friendship at beautiful Pratt Wayne Woods. Really, it was cold as hell, my plane was not flying well, and I was bugging Hymie to give me a hand. (Hymie was great and I love him.)

In between flights and trying to keep warm, I noticed a couple of planes that looked somewhat similar against that dreary, cloudy, grey/blue sky.

I thought either we shouldn't be flying today or the planes and colors should really be distinctive.

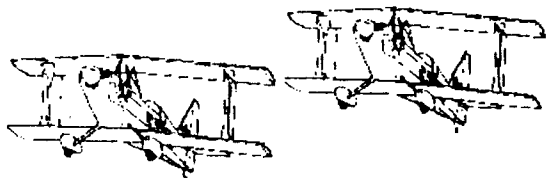

Well folks, I heard a great story that needs repeating. It seems that two guys were flying very similar planes. From what I heard, they were pretty close to being identical. The two were flying very skillfully, fast, aerobatic, and having a good time. As both were looking up in the direction of the plane (get the picture - singular plane), one thought the plane was not behaving in the direction and movement of the controls.

What could have gone through his mind at the moment of realization that "Hey, that ain't my plane." He scans the sky nervously, not seeing anything he becomes apprehensive. At the same moment, he sees a spec in the corner of his eye. "If that's my plane, I might be able to save it." With that thought, it buried into the ground.

Who were these two flyers. No doubt, you would think they were newer flyers with very little experience. As a matter of fact, you would think it was me and a friend -- wrong alligator breath. It was not a beginner with very little experience and not me.

To tell the truth, I can't tell. I was sworn to secrecy. The only thing I can say is one of them taught me how to fly (now you have an idea how good this guy is), and his good buddy is a great flier and trusted officer of our club.



## **"PROFILES"**

by Gus Pasquini

I can't think of a more logical and deserving person to showcase in this new feature than Orvil Fluharty. In my short time with the Brainstormers, Orv has been one of the most active members, involving himself in a variety of activities focusing on our monthly newsletter and the Swap Meet.

Orv is 49, married, and has three children, Mike, Ken, and Lori. He is employed at United Airlines as a mechanic.

In 1962, while in the service, he started flying control line. No one particularly influenced Orv, and no one really gave him any instructions. As he said, he just started. His first RC plane was a Junior Falcon, built and flown in 1968. He used a single channel Citizenship Radio which caused the plane to "fly away" several times (if you recall, Dave Patrick mentioned this in his presentation: same plane, same radio, same problem).

After several spectacular "dorks" and rebuilding jobs, Orv dropped out of the hobby for approximately 12 years. Around 1980-81, he resurrected his interest and with the help of a friend began flying again. His favorite plane is his Clipped Wing Cub.

Orv's building tip is after using balsa filler, sand well and put a few drops of C.A. on the mixture. It will set up like concrete.

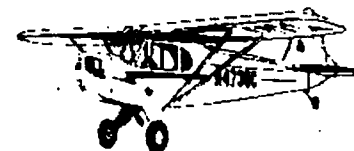

The flying tip is "get help from an instructor." Don't do it alone. He emphasized this point with an interesting anecdote about a friend who thought he could do it alone with his first plane being a CAP 21.

Orv, keep up the good work for the organization. I know everyone appreciates your efforts.



# RC BATTERY BACKUP-UP SYSTEM

## The Easy Way

by George Steiner

*This article is a condensation of an article written for one of the Model Airplane magazines. I wish I could remember which magazine and what month, but suffice it to say it was Model Airplane News or RC Modeler within the last six months. S. R. Taylor*

One of the highest priority maintenance items for R/C use these days are the battery power systems we use. The unforgiving NiCd batteries and associated wiring connections have a higher risk of failure than any other part operating our R/C models. The most common failure (if a survey was taken) is **battery problems**. It is said that a single ended power system can present a 95% failure rate. In most cases we get by with what the manufacturer has give us, a single battery pack with a single positive an negative wire to provide power to that remote R/C system. Existing systems are reliable enough, but improving the power source and reducing the battery power loss while the model is flying should seem a worthwhile venture.

Taking a look at the R/C airborne power requirements, we find the typical NiCd begins to run out of power at 4.4 volts. At this point, power on demand takes a nose dive. Most receiver systems will operate down to 3.8 volts providing the source is stable. The servos are much more tolerant and will operate (very slow transit time) at 3.5 volts or less. With these requirements, a standby power source that would come alive at 4.5 volts automatically would save the day. (One in a thousand are the odds, but is one to many?)

In devising this **save your airplane** from a main power source failure, we used the KISS (Keep It Simple, Stupid) principals. All it takes are some simple parts from Radio Shack and an extra switch harness. The drawing identified as Figure 1 shows the wiring connections that provides the battery on standby. Installations is simple, just plug the standby power into an unused channel output. **Note:** if all channels are in use, a "Y" harness connection can be used and simply plugged into any channel. Here's how it works: Using four alkaline batteries for the standby power, the system operates through two power diodes in series which lowers the voltage to 4.51 volts. Voltage drop across each diode is 0.7 volts and the combined voltage drop is enough to cause the LED to light when power is drawn from the standby power source. With the standby power of approximately 4.9 volts, lowered through the diodes, no power is consumed from the alkaline standby batteries because they are reversed biased through these power diodes. Not until the main source fails, or drops to the standby battery voltage,

does the standby power give a boost to the failing main power. It's as simple as that, and by using alkaline batteries, you have an available power on demand of 1.2 amps, with an estimated usable life of over 100 flight hours before they should have to be replaced. Alkaline batteries have a very smooth receding power curve with no critical voltage drop off point like the NiCd has at 4.4 volts.

This would assure you that when the standby power is in use it would supply the demand of your R/C system power needs. There's no need to recharge this redundant power source; all you have to do is tuck it away some place in you model an forget about it. However, occasionally the standby power voltage should be tested to ensure it is adequate. Minimum load test voltage would be 3.9 volts with an ESV.

An operational test is performed by turning on both switch harnesses to power up the R/C system. Then switch off the main power source and the standby power will take over. The LED load indicator will flicker on when operating the servos. Now, by switching back on the main power, the LED load indicator will stop flickering to show that the main system is ready for use.

### Parts List

#### Sources - Radio Shack & Ace R/C

- 2 - 1N4001 Diodes (RS #276-1101) (Ace #SS120)
- 1 - LED Red (RS #276-041) (Ace #SS075)
- 1 - Battery Holder (RS #270-391)
- 1 - Switch Harness for your receiver (or Ace #19G702)

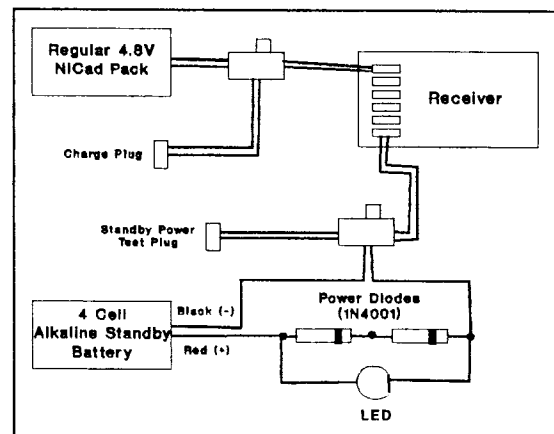

Figure 1. Circuit Layout

## FREQUENCY SURVEY UPDATE

S. R. Taylor

Here is an update of the club frequency survey. To date, 74 out of 132 members have responded to the survey. Some interesting patterns are beginning to emerge. There is almost a linear increase in the number of users per channel as the channel numbers increase. Also, the majority of members using the new odd channels are using channel numbers below channel 36. Perhaps this is due to the manufacturers limiting production of odd channels to the lower channel numbers first. The amateur radio frequencies are not shown on the graph, but the information will remain on file.

Keep those survey forms coming, we will continue to report on the frequency survey as information is received and updated. Survey forms will continue to be available at the club meetings.

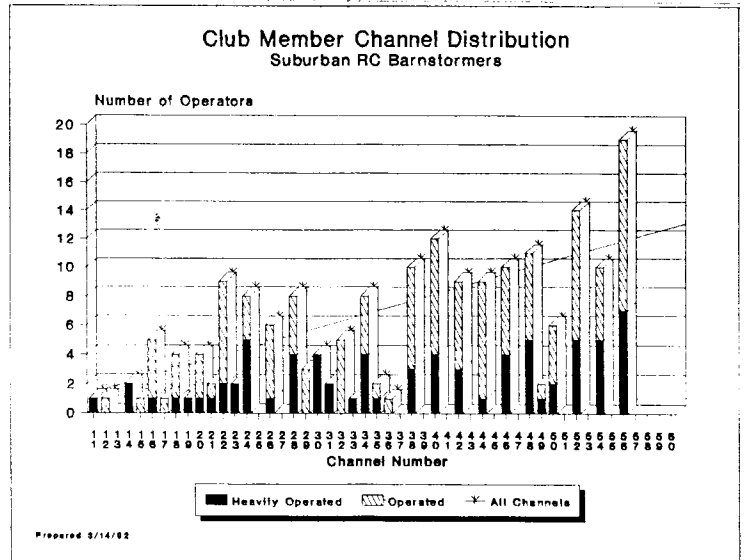

## SWAP TIL' YOU DROP..

Now that Swap Shop 92 has come and gone I need to thank a lot of people. I think that modestly speaking this was the best year ever. Not because we sold 99 out of 101 tables, not because we completely sold out of food, not because we had one of the best static displays ever, not because we had more people come through the door than ever before, not because of the excellent support from our fellow clubs. Yes all these things are very important and our thanks goes out to all those clubs who helped us, the sellers, and those who attended. But the thing that stands out the most is the giant turnout of our members who worked there butts off loading and unloading cars, working the check-in tables, cooking and selling the food, selling raffle tickets, setting up and keeping the static area secure and on and on. I think the image presented by our club and members at this event is worth more than every penny we made...

So til' we do it all again next year, **thanks**

*Eric*



THE FOX VALLEY AERO CLUB  
OF ST. CHARLES, IL.

R/C AIRPLANE,  
CAR AND BOAT

# SWAP SHOP

SATURDAY,  
APRIL 11, 1992

WEST SIDE  
SPORTS CENTER  
ST. CHARLES, IL

\*\*\*  
SET-UP 7:30 TO 9:00 A.M.  
\*\*\*  
ADMISSION: 9:00 TO 3:00 P.M.  
\*\*\*  
ADMISSION: \$2.00  
CHILDREN UNDER 12 FREE  
\*\*\*  
TABLES: \$10.00 EACH  
\*\*\*  
FOR MORE  
INFORMATION:  
ERIC KARI  
(708) 365-9434

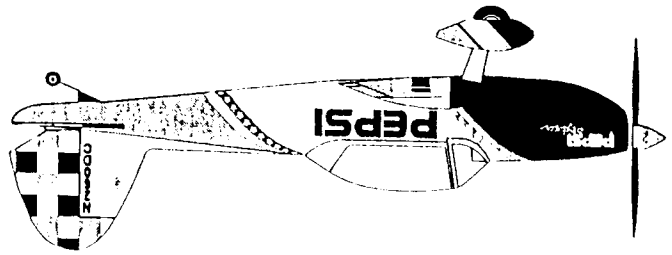

SUBURBAN R.C. BARNSTORMERS ORVIL FLUHARTY 899 CARL AVE. ELGIN IL. 60120

29 USA

THE TRANSMITTER



# 1992 SCHEDULE

JANUARY	9th BUSINESS MEETING.	JULY	5th GIANT SCALE FUN/FLY.
JANUARY	23rd ENTERTAINMENT MEETING.	JULY	9th BUSINESS MEETING.
FEBRUARY	13th BUSINESS MEETING.	JULY	23rd FIELD MEETING.
FEBRUARY	27th ENTERTAINMENT MEETING.	JULY	12th FUN/FLY #3.
MARCH	12th BUSINESS MEETING.	JULY	26th BARNSTORMERS VS LISLE.
MARCH	14th SWAP TIL YOU DROP 1V HEMMENS AUDITORIUM ELGIN.	AUGUST	9th FUN/FLY #4.
MARCH	26th ENTERTAINMENT MEETING.	AUGUST	13TH FIELD MEETING.
APRIL	9th BUSINESS MEETING.	AUGUST	23rd IMAA VETERANS MEM.
APRIL	23rd MTG AND STATIC CONTEST.	AUGUST	27TH BUSINESS MEETING.
MAY	3rd GIANT SCALE FUN/FLY.	SEPTEMBER	10th FIELD MEETING.
MAY	14th BUSINESS MEETING.	SEPTEMBER	13th FUN/FLY #5.
MAY	17th FUN/FLY #1.	SEPTEMBER	24TH BUSINESS MEETING.
MAY	28th FIELD MEETING.	OCTOBER	8th BUSS. MTG NOMINATIONS.
JUNE	11th BUSINESS MEETING.	OCTOBER	22nd ENTERTAINMENT MTG.
JUNE	25th FIELD MEETING.	NOVEMBER	12th BUSS. MTG. AND ELECTIONS.
JUNE	21st FUN/FLY #2.	DECEMBER	10th BUSS. MTG. XMAS RAFFLE.